

## WALL TYPE AXIAL EXPLOSION PROOF FAN

# AIR HC SERIES



\*Impeller with adjustable pitch angle for maximum efficiency aluminum hub and blades. Aluminium anti-spark ring.

\*Resistant to electrostatic powder coated corrosion. Hot dip galvanized steel is available upon request.

\*The motor is speed controllable by frequency converter.

\*Optional square mounting console and round mounting console options are available.

\* Products are fully ATEX certified.

\* Exproof Protection Class: EX IIG IIC T6.

\*Suitable for outdoor use.

### Technical details;

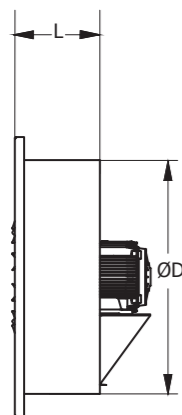
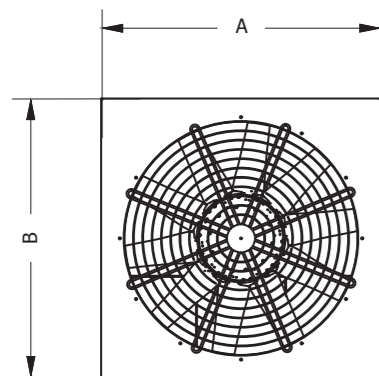

MODELS	DIMENSIONS (mm)			
	A	B	L	ØD
AIR HC 31-2-4T	500	500	300	315
AIR HC 35-2-4T	500	500	300	355
AIR HC 40-2-4T	550	550	300	400
AIR HC 45-2-4T	600	600	300	450
AIR HC 63-2-4T	800	800	350	630
AIR HC 71-2-4T	900	900	350	710
AIR HC 80-2-4T	1000	1000	350	800
AIR HC 90-2-4T	1100	1100	350	900
AIR HC 100-2-4T	1200	1200	350	1000
AIR HC 112-2-4T	1400	1400	350	1120

MODEL	PRODUCT CODE	Airflow (m³/h)	PWR (KW)	Sound (dBA)	Current (AMP)	Rotation (RPM)	VOLTAGE (V)	Weight (KG)
AIR HC 31-2T-0,18	52001	3157	0,18	85	0,65	2785	380	22
AIR HC 31-2T-0,25	52002	3740	0,25	86	0,70	2755	380	23
AIR HC 35-2T-0,37	52003	4664	0,37	83	1,10	2760	380	26
AIR HC 40-2T-0,55	52004	5962	0,55	91	1,45	2760	380	30
AIR HC 40-2T-0,75	52005	7315	0,75	88	1,85	2800	380	33
AIR HC 45-2T-0,75	52006	8459	0,75	95	1,85	2800	380	36
AIR HC 45-2T-1,1	52007	12100	1,10	92	2,60	2790	380	37
AIR HC 45-2T-1,5	52008	12100	1,50	91	3,25	2865	380	40
AIR HC 45-2T-2,2	52009	14740	2,20	94	4,75	2875	380	42
AIR HC 63-2T-2,2	52010	19800	2,20	97	4,75	2875	380	55
AIR HC 63-2T-3	52011	22000	3,00	96	6,45	2875	380	62
AIR HC 63-2T-4	52012	26070	4,00	96	7,50	2865	380	68
AIR HC 71-2T-5,5	52013	33880	5,50	99	9,80	2890	380	75
AIR HC 71-2T-7,5	52014	39270	7,50	100	13,60	2910	380	79
AIR HC 71-2T-11	52015	45650	11,00	101	19,50	2945	380	85
AIR HC 35-4T-0,12	52016	3729	0,12	71	0,65	1380	380	23
AIR HC 40-4T-0,18	52017	5181	0,18	73	0,75	1330	380	27
AIR HC 40-4T-0,25	52018	5544	0,25	76	1,05	1320	380	28
AIR HC 45-4T-0,37	52019	7766	0,37	80	1,35	1425	380	33
AIR HC 45-4T-0,55	52020	8822	0,55	79	1,50	1690	380	35
AIR HC 63-4T-1,1	52021	15290	1,10	85	2,80	1705	380	55
AIR HC 63-4T-1,5	52022	20350	1,50	86	3,55	1700	380	57
AIR HC 63-4T-2,2	52023	22990	2,20	89	4,90	1715	380	64
AIR HC 71-4T-3	52024	29590	3,00	91	7,70	1710	380	73
AIR HC 71-4T-4	52025	32340	4,00	93	8,50	1735	380	77
AIR HC 80-4T-3	52026	35200	3,00	91	6,60	1435	380	82
AIR HC 80-4T-4	52027	40040	4,00	93	8,20	1455	380	86
AIR HC 80-4T-5,5	52028	43120	5,50	95	11,20	1465	380	96
AIR HC 90-4T-3	52029	38500	3,00	96	6,60	1435	380	100
AIR HC 90-4T-4	52030	45320	4,00	96	8,20	1455	380	104
AIR HC 90-4T-5,5	52031	47410	5,50	95	11,20	1465	380	116
AIR HC 90-4T-7,5	52032	55110	7,50	101	15,40	1465	380	126
AIR HC 100-4T-5,5	52033	55330	5,50	97	11,20	1465	380	124
AIR HC 100-4T-7,5	52034	62480	7,50	99	15,40	1465	380	134
AIR HC 112-4T-5,5	52035	59070	5,50	102	11,20	1465	380	133
AIR HC 112-4T-7,5	52036	75680	7,50	100	15,40	1465	380	145